

Technical Specifications

Geoflex Dehumidification System
Model 042 - 410A - Top Discharge

Blower High Speed CFM & SP

ESP	0.3	0.5	.75	1.0
CFM	1,514	1,400	1,322	1,284

Standard Pool Heat Recovery Option

Model	GPM	FOH	PSIG	MBH	EWT
DWV-1.0	2	2.1	0.9	12	80
DWV-1.5	3	5.3	2.3	18	80

Available Cabinet Types

Model	Cabinet Types	Footprint		Height without Damper	Height c/w 8" Damper
		Width	Depth		
042	Standard Vertical	29.5"	29.5"	54.0"	62.0"
042	*Larger Vertical	29.5"	44.25"	54.0"	62.0"
042	Standard Horizontal	29.5"	59.0"	29.0"	37.0"
042	**Compact Horizontal	29.5"	44.25"	29.0"	37.0"

* Larger cabinets are used to accommodate much higher than standard CFM
** Units with some features, eg., the geothermal option, demand a larger footprint

NOTE: Weights and measures can vary, depending on selected configuration and options!

Elements	
Description	Type
Refrigerant	R410A
Refrigerant Charge (Superheat Supercooled)	Min 10 F Superheat
Base Unit	4.0 lbs. (est)
Base Unit c/w Ext. DX Condenser	6.3 lbs. (est)
Internal 100% Air Reheat Condenser	DX (Direct Expansion)
Compressor	Scroll
Standard Blower	Direct Drive (PSC or ECM)
Air Coil Coating	Baked Acrylic 3 Stage Process
Condensate Pan	SuperGard Coated
Optional Pool Reheat Condenser	Co-axial (DWV, C/N)
Optional Water Condenser	Co-axial or Brazed Plate
Base Weight	470 lbs. (est)
Ship Weight	500 lbs. (est)
Crated Weight	530 lbs. (est)

Standard Features	
Internal Piping	All Internal Refrigeration Piping is Insulated to Reduce Noise and Potential Pipe Degradation
Air Coils	Air Coils and internal components are coated and baked with an Acrylic Coating
Low Noise Package	1" acoustical insulation & all internal refrigeration lines are fully insulated to reduce noise potential.
Electronic Diagnostics	On board fault Diagnostics
Cabinet	A Separator Plate is used between the Air and Refrigeration Section
Service & Maintenance	Service Doors Surround System
Refrigeration Section	An Internal Negative Pressure Port is incorporated to Reduce Heat or Condensation Build-up.
Service Switches	Two Low, One High Pressure switch Safety Controls, with Memory
Freon Service	Bi-flow Filter/Drier & Moisture Indicating Sight Glass
Condensate Sensor	Electronic Condensate Pan Overflow Sensor is included in all Dehumidification Systems.
Condensate Line Position	Systems come with a condensation line that can be adapted to any corner of the system, in the field!
Evaporator Construction	All Evaporator Coils are Insulated to avoid Condensation Rusting
Field Adaption	All Systems are designed to offer maximum field adaptability

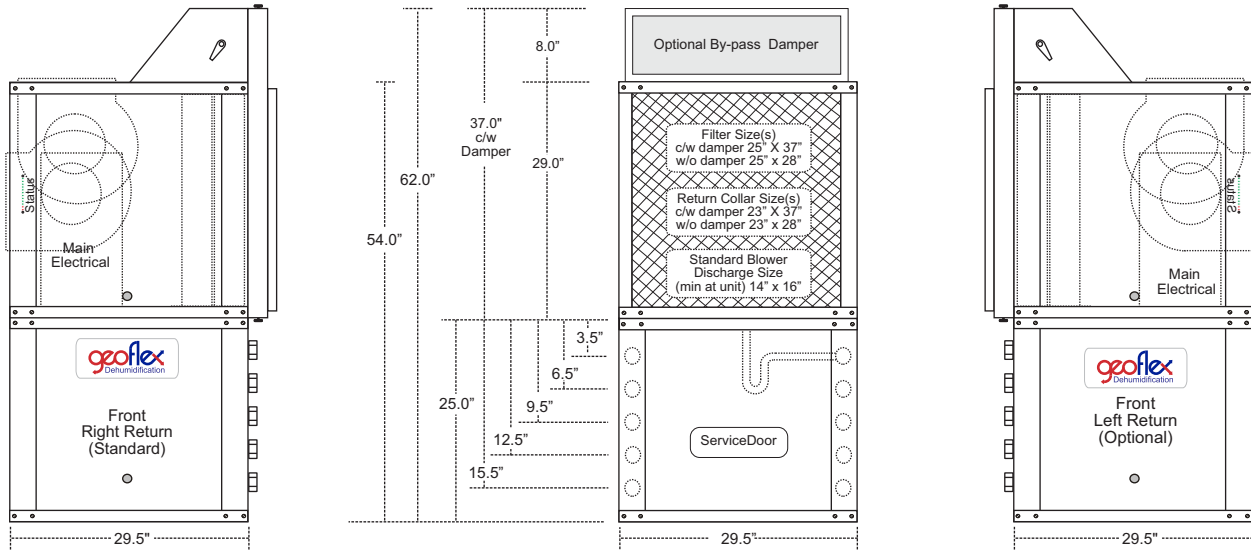

410A Single Step Dehumidification Performance Data													
Model	Fan Motor Type	Spd	Air Temp °F	RH 50%			RH 55%			RH 60%			Flow Indoor Air CFM
				Mositure Removal lbs/hr	Sensible Cooling Btuh	Total Capacity Btuh	Mositure Removal lbs/hr	Sensible Cooling Btuh	Total Capacity Btuh	Mositure Removal lbs/hr	Sensible Cooling Btuh	Total Capacity Btuh	
042	PSC	Full	80	10.5	22,900	33,618	11.6	21,884	34,045	13.9	21,551	35,236	1,400
	PSC	Full	82	10.9	22,220	32,818	13.1	21,386	33,430	14.3	20,731	34,178	
	PSC	Full	84	13.3	21,551	32,032	16.0	20,813	32,724	17.5	20,089	33,349	

Single Step, 410A Electrical Data													
Model	Voltage Code	Voltage	Min/Max Voltage	Compressor			Blower Hp	Blower FLA	Total Unit FLA	Min Circuit Amps	Max Fuse/HACR	Supply Wire	
				RLA	LRA	LRA*						Min AWG	Max Ft (M)
42	A	208-230/60/1	197/254	16.7	79.0	27.7	.5	3.8	21.0	25.2	35	10	66 (20.1)
	C	208-230/60/3	197/254	10.1	73.0		.5	2.8	13.4	16.1	20	14	95 (29.0)
	D	460/60/3	414/506	5.4	38.0		.5	1.3	7.2	8.7	10	14	341 (104.0)
	E	575/60/3	518/633	3.8	36.5		.5	1.0	5.3	6.3	10	14	650 (198.3)

Notes: LRA* estimated with optional "Secure Start" installed (208-230/60/1)
HACR circuit breaker in USA only All fuses Class RK-5

Wire length based on higher if 2 voltages, one way 2.0% voltage drop
Wire size based on 60°C copper conductor & minimum circuit ampacity



Geoflex Systems are QPS approved
GF-DH&WA-SS-TD-048-07-14-13-1
all rights reserved ©2006 geoflex systems inc.
Due to ongoing research and development Geoflex reserves the right to change or alter specifications and configurations without notice!

www.geoflexsystems.com

Plant & Office:
517 McCormick Blvd., London, Ontario N5W 4C8
Phone: 519.488.1653 Fax: 519.913.1259
Email: plant@geoflexsystems.com

Technical Specifications

Geoflex Dehumidification System
Model 042 - 410A - Bottom Discharge

Blower High Speed CFM & SP

ESP	0.3	0.5	.75	1.0
CFM	1,514	1,400	1,322	1,284

Standard Pool Heat Recovery Option

Model	GPM	FOH	PSIG	MBH	EWT
DWV-1.0	2	2.1	0.9	12	80
DWV-1.5	3	5.3	2.3	18	80

Available Cabinet Types

Model	Cabinet Types	Footprint		Height without Damper	Height c/w 8" Damper
		Width	Depth		
042	Standard Vertical	29.5"	29.5"	54.0"	62.0"
042	*Larger Vertical	29.5"	44.25"	54.0"	62.0"
042	Standard Horizontal	29.5"	59.0"	29.0"	37.0"
042	**Compact Horizontal	29.5"	44.25"	29.0"	37.0"

* Larger cabinets are used to accommodate much higher than standard CFM
** Units with some features, eg., the geothermal option, demand a larger footprint

NOTE: Weights and measures can vary, depending on selected configuration and options!

Elements	
Description	Type
Refrigerant	R410A
Refrigerant Charge (Superheat Supercooled)	Min 10 F Superheat
Base Unit	4.0 lbs. (est)
Base Unit c/w Ext. DX Condenser	6.3 lbs. (est)
Internal 100% Air Reheat Condenser	DX (Direct Expansion)
Compressor	Scroll
Standard Blower	Direct Drive (PSC or ECM)
Air Coil Coating	Baked Acrylic 3 Stage Process
Condensate Pan	SuperGard Coated
Optional Pool Reheat Condenser	Co-axial (DWV, C/N)
Optional Water Condenser	Co-axial or Brazed Plate
Base Weight	470 lbs. (est)
Ship Weight	500 lbs. (est)
Crated Weight	530 lbs. (est)

Standard Features	
Internal Piping	All Internal Refrigeration Piping is Insulated to Reduce Noise and Potential Pipe Degradation
Air Coils	Air Coils and internal components are coated and baked with an Acrylic Coating
Low Noise Package	1" acoustical insulation & all internal refrigeration lines are fully insulated to reduce noise potential.
Electronic Diagnostics	On board fault Diagnostics
Cabinet	A Separator Plate is used between the Air and Refrigeration Section
Service & Maintenance	Service Doors Surround System
Refrigeration Section	An Internal Negative Pressure Port is incorporated to Reduce Heat or Condensation Build-up.
Service Switches	Two Low, One High Pressure switch Safety Controls, with Memory
Freon Service	Bi-flow Filter/Drier & Moisture Indicating Sight Glass
Condensate Sensor	Electronic Condensate Pan Overflow Sensor is included in all Dehumidification Systems.
Condensate Line Position	Systems come with a condensation line that can be adapted to any corner of the system, in the field!
Evaporator Construction	All Evaporator Coils are Insulated to avoid Condensation Rusting
Field Adaption	All Systems are designed to offer maximum field adaptability

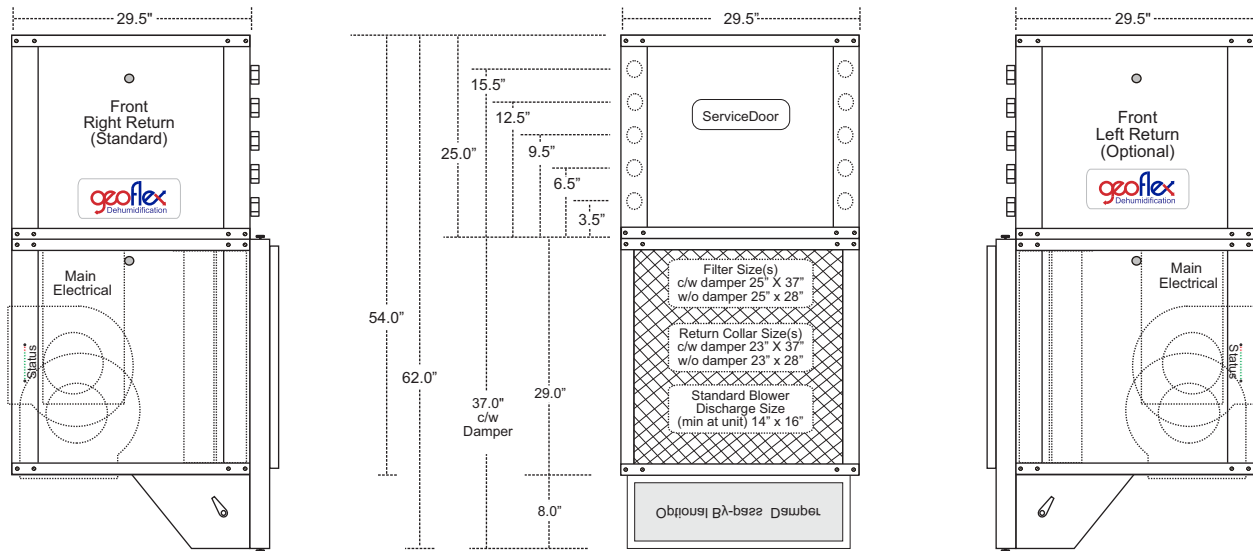

410A Single Step Dehumidification Performance Data													
Model	Fan Motor Type	Spd	Air Temp °F	RH 50%			RH 55%			RH 60%			Flow Indoor Air CFM
				Mositure Removal lbs/hr	Sensible Cooling Btuh	Total Capacity Btuh	Mositure Removal lbs/hr	Sensible Cooling Btuh	Total Capacity Btuh	Mositure Removal lbs/hr	Sensible Cooling Btuh	Total Capacity Btuh	
042	PSC	Full	80	10.5	22,900	33,618	11.6	21,884	34,045	13.9	21,551	35,236	1,400
	PSC	Full	82	10.9	22,220	32,818	13.1	21,386	33,430	14.3	20,731	34,178	
	PSC	Full	84	13.3	21,551	32,032	16.0	20,813	32,724	17.5	20,089	33,349	

Single Step, 410A Electrical Data													
Model	Voltage Code	Voltage	Min/Max Voltage	Compressor			Blower Hp	Blower FLA	Total Unit FLA	Min Circuit Amps	Max Fuse/HACR	Supply Wire	
				RLA	LRA	LRA*						Min AWG	Max Ft (M)
42	A	208-230/60/1	197/254	16.7	79.0	27.7	.5	3.8	21.0	25.2	35	10	66 (20.1)
	C	208-230/60/3	197/254	10.1	73.0		.5	2.8	13.4	16.1	20	14	95 (29.0)
	D	460/60/3	414/506	5.4	38.0		.5	1.3	7.2	8.7	10	14	341 (104.0)
	E	575/60/3	518/633	3.8	36.5		.5	1.0	5.3	6.3	10	14	650 (198.3)

Notes: LRA* estimated with optional "Secure Start" installed (208-230/60/1)
HACR circuit breaker in USA only All fuses Class RK-5

Wire length based on higher if 2 voltages, one way 2.0% voltage drop
Wire size based on 60°C copper conductor & minimum circuit ampacity



Geoflex Systems are QPS approved
GF-DH&WA-SS-TD-048-07-14-13-1
all rights reserved ©2006 geoflex systems inc.
Due to ongoing research and development Geoflex reserves the right to change or alter specifications and configurations without notice!

www.geoflexsystems.com

Plant & Office:
517 McCormick Blvd., London, Ontario N5W 4C8
Phone: 519.488.1653 Fax: 519.913.1259
Email: plant@geoflexsystems.com

Technical Specifications

Geoflex Dehumidification System
Model 042 - 410A - Horizontal

Blower High Speed CFM & SP

ESP	0.3	0.5	.75	1.0
CFM	1,514	1,400	1,322	1,284

Standard Pool Heat Recovery Option

Model	GPM	FOH	PSIG	MBH	EWI
DWV-1.0	2	2.1	0.9	12	80
DWV-1.5	3	5.3	2.3	18	80

Available Cabinet Types

Model	Cabinet Types	Footprint		Height without Damper	Height c/w 8" Damper
		Width	Depth		
042	Standard Vertical	29.5"	29.5"	54.0"	62.0"
042	*Larger Vertical	29.5"	44.25"	54.0"	62.0"
042	Standard Horizontal	29.5"	59.0"	29.0"	37.0"
042	**Compact Horizontal	29.5"	44.25"	29.0"	37.0"

* Larger cabinets are used to accommodate much higher than standard CFM
** Units with some features, eg., the geothermal option, demand a larger footprint

NOTE: Weights and measures can vary, depending on selected configuration and options!

Elements	
Description	Type
Refrigerant	R410A
Refrigerant Charge (Superheat Supercooled)	Min 10 F Superheat
Base Unit	4.0 lbs. (est)
Base Unit c/w Ext. DX Condenser	6.3 lbs. (est)
Internal 100% Air Reheat Condenser	DX (Direct Expansion)
Compressor	Scroll
Standard Blower	Direct Drive (PSC or ECM)
Air Coil Coating	Baked Acrylic 3 Stage Process
Condensate Pan	SuperGaurd Coated
Optional Pool Reheat Condenser	Co-axial (DWV, C/N)
Optional Water Condenser	Co-axial or Brazed Plate
Base Weight	470 lbs. (est)
Ship Weight	500 lbs. (est)
Crated Weight	530 lbs. (est)

Standard Features	
Internal Piping	All Internal Refrigeration Piping is Insulated to Reduce Noise and Potential Pipe Degradation
Air Coils	Air Coils and internal components are coated and baked with an Acrylic Coating
Low Noise Package	1" acoustical insulation & all internal refrigeration lines are fully insulated to reduce noise potential.
Electronic Diagnostics	On board fault Diagnostics
Cabinet	A Separator Plate is used between the Air and Refrigeration Section
Service & Maintenance	Service Doors Surround System
Refrigeration Section	An Internal Negative Pressure Port is incorporated to Reduce Heat or Condensation Build-up.
Service Switches	Two Low, One High Pressure switch Safety Controls, with Memory
Freon Service	Bi-flow Filter/Drier & Moisture Indicating Sight Glass
Condensate Sensor	Electronic Condensate Pan Overflow Sensor is included in all Dehumidification Systems.
Condensate Line Position	Systems come with a condensation line that can be adapted to any corner of the system, in the field!
Evaporator Construction	All Evaporator Coils are Insulated to avoid Condensation Rusting
Field Adaption	All Systems are designed to offer maximum field adaptability

Notes: As Geoflex offers a wide variety of features, configurations and options, weights and measures can vary, depending on options!

The main electrical box positioning can vary, depending on features, options and field requirements.

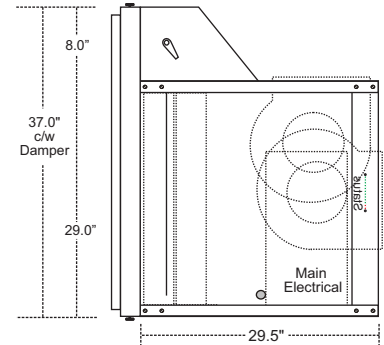
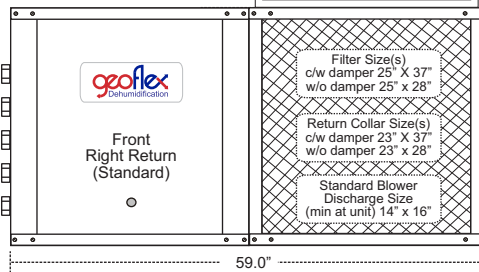
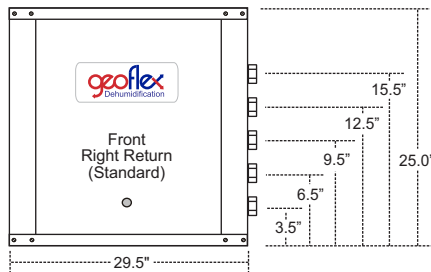
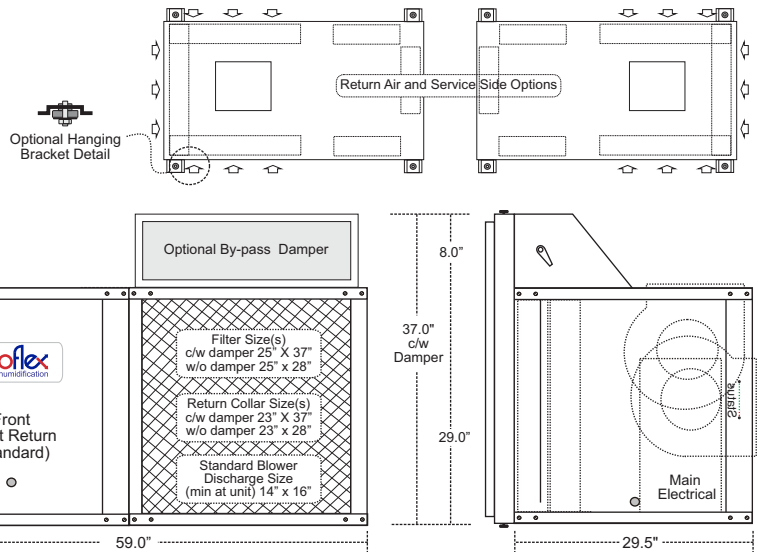

410A Single Step Dehumidification Performance Data

Model	Fan Motor Type	Spd	Air Temp °F	RH 50%			RH 55%			RH 60%			Flow Indoor Air CFM
				Moisture Removal lbs/hr	Sensible Cooling Btuh	Total Capacity Btuh	Moisture Removal lbs/hr	Sensible Cooling Btuh	Total Capacity Btuh	Moisture Removal lbs/hr	Sensible Cooling Btuh	Total Capacity Btuh	
042	PSC	Full	80	10.5	22,900	33,618	11.6	21,884	34,045	13.9	21,551	35,236	1,400
	PSC	Full	82	10.9	22,220	32,818	13.1	21,386	33,430	14.3	20,731	34,178	
	PSC	Full	84	13.3	21,551	32,032	16.0	20,813	32,724	17.5	20,089	33,349	

Single Step, 410A Electrical Data

Model	Voltage Code	Voltage	Min/Max Voltage	Compressor			Blower Hp	Blower FLA	Total Unit FLA	Min Circuit Amps	Max Fuse/HACR	Supply Wire	
				RLA	LRA	LRA*						Min AWG	Max Ft (M)
42	A	208-230/60/1	197/254	16.7	79.0	27.7	.5	3.8	21.0	25.2	35	10	66 (20.1)
	C	208-230/60/3	197/254	10.1	73.0		.5	2.8	13.4	16.1	20	14	95 (29.0)
	D	460/60/3	414/506	5.4	38.0		.5	1.3	7.2	8.7	10	14	341 (104.0)
	E	575/60/3	518/633	3.8	36.5		.5	1.0	5.3	6.3	10	14	650 (198.3)

Notes: LRA* estimated with optional "Secure Start" installed (208-230/60/1)
HACR circuit breaker in USA only All fuses Class RK-5

Wire length based on higher if 2 voltages, one way 2.0% voltage drop
Wire size based on 60°C copper conductor & minimum circuit ampacity



Geoflex Systems are QPS approved
GF-DH&WA-SS-TD-048-07-14-13-2
all rights reserved ©2006 geoflex systems inc.
Due to ongoing research and development Geoflex reserves the right to change or alter specifications and configurations without notice!

www.geoflexsystems.com

Plant & Office:
517 McCormick Blvd., London, Ontario N5W 4C8
Phone: 519.488.1653 Fax: 519.913.1259
Email: plant@geoflexsystems.com